



CHONG YI
TECHNOLOGY

CYLMBPV11

Control Card Hardware

Instruction Manual

Beijing Chongyi Technology Co., Ltd.

Content

1. V1.1 System Control Card Wiring Definition and Description	5
1.1 Power Supply	7
1.2 Input and Output Interface	7
1.3 Galvo Head Control.....	8
1.4 Laser Source Interface	9
1.4.1 Fiber Laser Pin Description	10
1.4.2 CO2 Glass Tube Pin Description	11
1.4.3 Pump Laser Pin Description	11
1.4.4 CO2 RF Tube Pin Description	11
2. Main Functions of the Control Card	12
3. Physical Picture of the Control Card.....	13

Preface

Beijing Chongyi Technology Co., Ltd. (CY Tech) is an advanced technology enterprise dedicated to the research, development and application of laser scanning systems. Since its establishment, the company has always focused on providing cutting-edge laser marking, laser cleaning, laser welding software systems and professional technical solutions to global customers. So far, the company has successfully applied for a number of copyright and patent certificates related to laser scanning software. As an enterprise with technology as its core, CY Tech has assembled a R&D team composed of a group of senior engineers and industry experts. Not only are they proficient in various laser scanning technologies and their applications, but they are also able to keenly capture market trends and customer needs and provide tailor-made solutions.

In the field of laser marking, CY Tech has developed a number of efficient and stable software systems. These software systems can be widely used in surface treatment of metals, non-metals, semiconductors and other materials to achieve precise and rapid marking. At the same time, the company also provides customers with one-stop services such as marking effect optimization and material adaptability testing to ensure that customers' products are competitive in the market.

For laser cleaning, CY Tech's R&D team broke through the bottleneck of traditional cleaning technology and developed an efficient and environmentally friendly laser cleaning software system. This system can be widely used for surface cleaning of

various materials, such as metal, plastic, glass, etc., solving various cleaning problems for customers.

What's more, we are also engage in laser welding's R&D, CY Tech also has rich experience and technology accumulation. The laser welding software system developed by the company has the characteristics of high precision, high speed and high stability, and can be widely used in automobile manufacturing, aerospace, electronics manufacturing and other industries.

In addition to providing software systems, CY Tech also provides customers with a full range of technical support and services. The company has a professional pre-sales team and after-sales team that can provide customers with timely and effective technical support and after-sales services. At the same time, the company also provides training and guidance to customers to help them better apply and maintain software systems. The company has strong R&D capabilities and a professional technical team to provide customers with high-quality and reliable technical services. If you need software systems and technical support for laser marking, laser cleaning, laser welding, etc., please contact us!

Security Information

1. Please read this section carefully before using the CYLMBPV11 control card. This product is a system used to control stepper motors. If you have any questions, please contact our company in time.
2. Please prevent the board from being damaged by moisture, dust, corrosion, and impact from foreign objects. When storing and using the board, please avoid damage by electromagnetic fields and static electricity.
3. Before starting the wiring, you need to carefully read the interface definition and instructions, and perform wiring according to the instructions to avoid damage to the board and peripherals.
4. When using it with other boards of our company, you need to read the instructions for use of the stepper motor related parts of the board.

1. V1.1 System Control Card Wiring Definition and Description

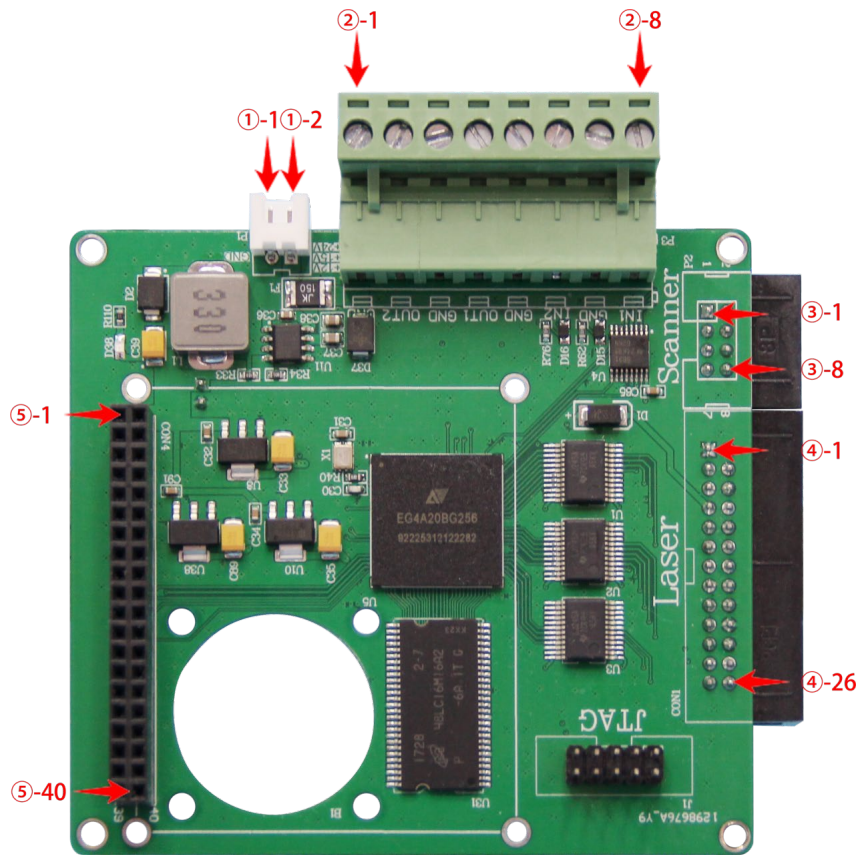

Figure 1-1 Control card interface labeling diagram

No.	Terminal	Functions	Cables order
①	System power supply	Provide power to the system	①-1: GND, ①-2: 12V/15V/24V
②	Input and output interface	IN1 triggers marking by default, IN2 software can be configured to stop marking; OUT1 power board controls power on and off, and OUT2 can configure the marking end output signal	②-1: GND, ②-2: OUT2, ②-3: GND, ②-4: OUT1, ②-5: GND, ②-6: GIN2, ②-7: GND, ②-8: GIN1

③	Galvo head interface	Used to output galvanometer control signals	③-1: CLK+, ③-2: CLK-, ③-3: SYNC+, ③-4: SYNC-, ③-5: XCHANNEL+, ③-6: XCHANNEL-, ③-7: YCHANNEL+, ③-8: YCHANNEL- See Table 1-(2) for details
④	Laser source interface	Used to output control laser related signals	See Table 1-(3) for details
⑤	Data processing control card interface	Marking data processing, interface display, touch and other operations	

Table 1-(1) External interface definition

1.1 Power Supply

The control card can be powered by 12V/15V/24V power supply. It is recommended to choose a 2A DC power supply.

1.2 Input and Output Interface

Port	Mode	Functions
IN1	Default	IN1 and GND short contact trigger marking
IN2	NONE	IN2 input is invalid
	LIFT TO STOP	Shorting IN2 and GND allows laser marking; IN2 is disconnected from GND, and IN1 trigger marking is invalid; During the marking process, GIN2 and GND are disconnected and marking stops.
	PRESS TO STOP	During the marking process, GIN2 and GND are short-circuited, and both laser marking and red-light preview stop.
OUT1	Default	Output level signals to the outside world. After clicking on power on, red light or marking in the main interface, a high-level signal will be output; after clicking on power off or entering standby mode (see software description), the level will be pulled down.
OUT2	Check the end signal	The level is pulled low before marking starts, pulled high after marking is completed, and the high level continues for a period of time and then pulled low. The high-level duration is set by software. In this mode, the level of GOUT2 is not affected by power-off and power-on states.
	End signal unchecked	GOUT2 and GOUT1 output signals are synchronized

Table 1-(2)

(Please refer to the touch screen software instructions)

1.3 Galvo Head Control

The galvo head control signal is a digital signal and can be directly connected to the digital galvo head.

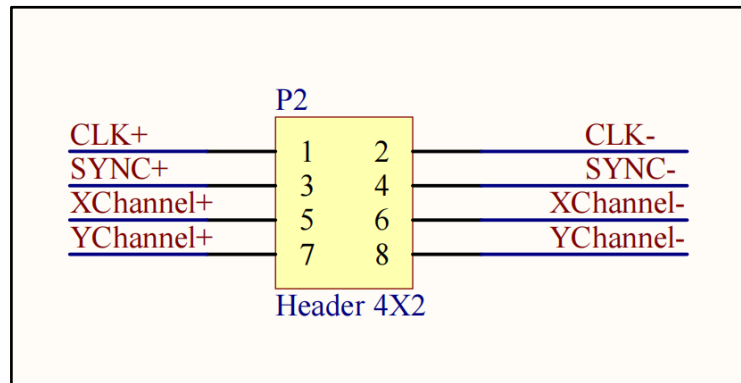

Figure 1-(2) Schematic diagram of galvo head pin definition

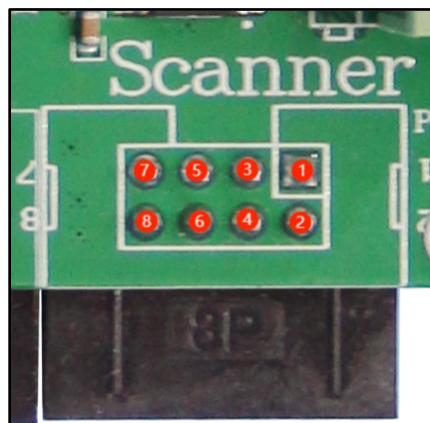

Figure 1-(3) Actual screenshots of the galvo head interface

Pin	Name	Note
1、 2	CLK+; CLK-	Galvo head synchronized clock
3、 4	SYNC+; SYNC-	Galvo head synchronization signal
5、 6	XCHANNEL+; XCHANNEL-	Galvo head X-axis data channel
7、 8	YCHANNEL+; YCHANNEL-	Galvo head Y-axis data channel

Table 1-(3)

For a dual-axis galvo head, you only need to connect four groups of eight signal lines: CLK, SYNC, X Channel, and Y channel. It is recommended that digital signals be connected using shielded twisted pairs.

1.4 Laser Source Interface

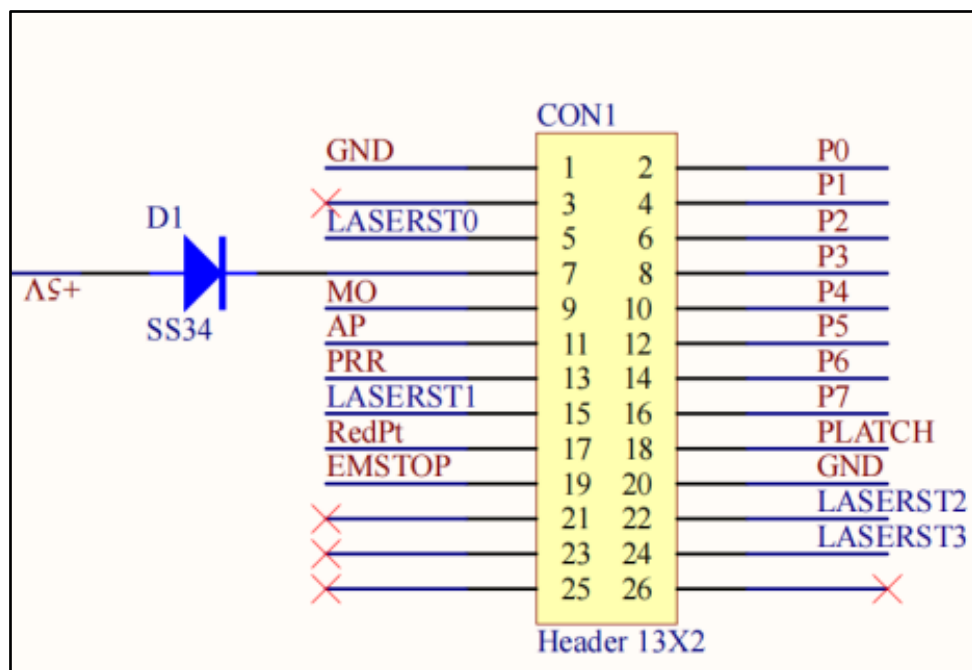

Figure 1-(4) Schematic diagram of laser interface pin definition

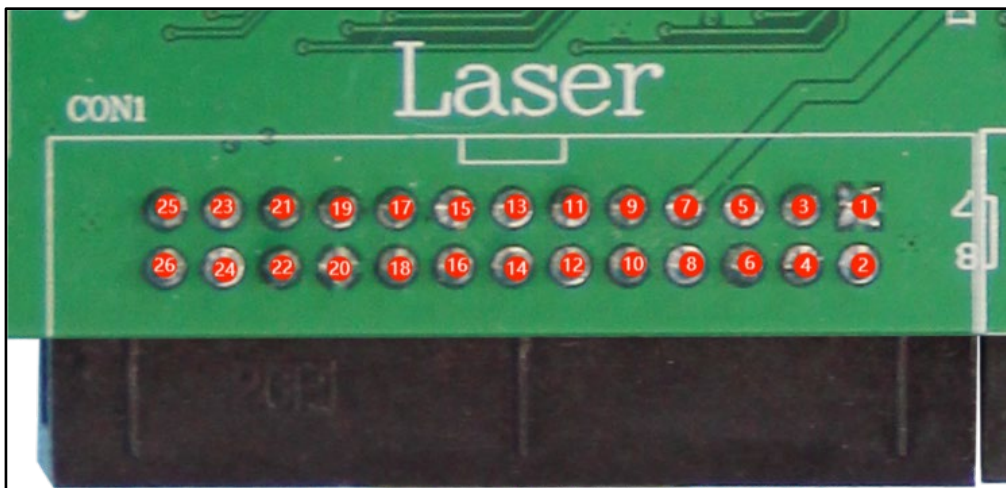

Figure 1-(5) Physical screenshot of the laser interface part

1.4.1 Fiber Laser Pin Description

Pin	Name	Note
2、4、6、8、10、12、14、16	P0~P7	Laser power value
18	PLATCH	Laser power value latch signal
5、15、22、24	LASERST0~LASERST3	Laser status
7	+5V	+5V power supply
9	MO	Main oscillator on
11	AP	Modulator on
13	PRR	Laser repetition pulse frequency
17	RedPt	Auxiliary infrared laser
19	EMSTOP	Emergency stop
1、20	GND	Digitally
3、21、23、25、26		None

Table 1-(4)

1.4.2 CO2 Glass Tube Pin Description

Pin	Name	Note
18	PLATCH	Switch Signal
12	P5	PWM Signal
20	GND	GND Signal

Table 1-(5)

1.4.3 Pump Laser Pin Description

Pin	Name	Note
18	PLATCH	Switch Signal
12	P5	PWM Signal
20	GND	GND Signal

Table 1-(6)

1.4.4 CO2 RF Tube Pin Description

Pin	Name	Note
13	PRR	PWM Signal
20	GND	GND Signal

Table 1-(7)

2. Main Functions of the Control Card

The CYLMBPV11 control card can perform laser marking and laser cleaning.

The CYLMBPV11 control card can support fiber laser, CO2 laser, UV laser and other types of lasers.

- Equipped with cleaning and marking functions
- Four USB interfaces for connecting external devices
- One network port, which can be connected through the network
- One HDMI interface, can be connected to an external screen
- Two inputs and two outputs (two 3.3V outputs)
- Support multiple laser types

3. Physical Picture of the Control Card



If any questions, please be free to contact us. Thank you.

Company: Beijing Chongyi Technology Co., Ltd.

E-Mail: sales01@bjchongyi.com

Web.: www.vipeylaser.com

We chat: chongyi0201

Whatsapp: +86 185 1158 5382

Address: Room 9001, 9th Floor, Building 2, No. 10, Baifuquan Road, Science &
Technology Park, Changping District, Beijing, China